

ER2M Dual Lifting
 Artikelnummer ER2M Dual Lifting



Omschrijving

Met standaard 10 meter stroomkabel.

Vrijblijvende lengte van ketting,
 afstandsbediening en lengte van
 stroomkabel.

Verlenging van de ketting is strikt verboden.

Stalen ketting container op aanvraag.



Standaard

Opties

Type

Specifications

Capacity (t)	Product Code	Hoist Body	Stand-ard Lift (m)	Push Button Cord L (m)	Lifting Motor		Lifting Speed (m/min)		Load Chain Diameter, Chain Falls	Cable color (optional)	Traversing Motor		Traversing Speed (m/min)		Range with B (mm)	Min. Radius Curve (mm)	Test Load (t)	Net Weight (kg)	Additional Weight per 1m Lift (kg)
					Output (kW)	Rating (kVA)	50Hz				Output (kW)	Rating (kVA)	50Hz						
							High	Low					High	Low					
125kg	ER2M001IH-IS	B			0.56	Phas. Adjust	10.6	2.8	4.3 x 1								156kg	50	0.42
250kg	ER2M003IS-IS					Phas. Adjust	10.8	1.5											
		ER2M003IH-IS	C		0.9	Phas. Adjust	15.7	2.5	6 x 1	M52m /-4				25 to 102	54 to 205		625kg	65	0.81
500kg	ER2M005IL-IS	Phas. Adjust				4.5	0.8	Phas. Adjust											
	ER2M005IS-IS	D	3	2.5	0.9	Phas. Adjust	8.5	1.4	7.7 x 1		0.4	27/13	Phas. Adjust	24 4		800	125	77	1.33
1	ER2M010IL-IS					Phas. Adjust	4.2	0.7											
	ER2M010IS-IS	E			1.8	Phas. Adjust	6.2	1.2	10.2 x 1								2	111	
1.6	ER2M016IS-IS					Phas. Adjust	5.3	0.9											
	ER2M020IL-IS	F			3.5	Phas. Adjust	4.3	0.7	11.2 x 1	M414m /-4							2.5	112	2.3
2	ER2M020IS-IS					Phas. Adjust	8.2	1.4											
	ER2M025IS-IS	E			2.8	Phas. Adjust	6.6	1.1	10.2 x 2								4	155	4.7
2.5	ER2M032IS-IS					Phas. Adjust	5.2	0.9											
	ER2M032IH-IS	F			3.5	Phas. Adjust	5.2	0.9	11.2 x 2		0.75						1900	6.25	200
3.2	ER2M050IS-IS					Phas. Adjust	3.3	0.8											
5	ER2M050IS-IS					Phas. Adjust	3.3	0.8											

Note: The minimum radius curve may depend on flange width. For further information, contact the nearest KITO dealer.
 The high speed is preset to the maximum speed in KITO factory. The speeds are adjustable between High and Low.

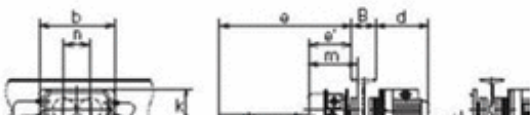

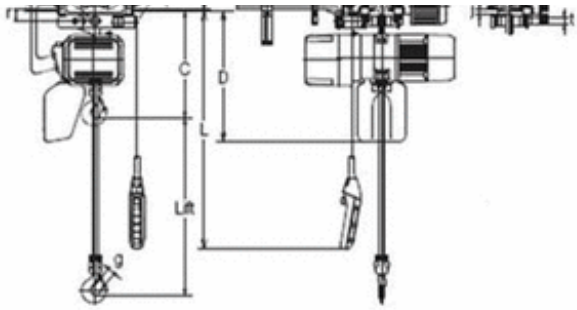

Dimensions (mm)

Capacity (t)	Product Code	Headroom C	D	b	d	e	e'	g	i	j	k	m	n	r	t
125kg	ER2M001IH-IS	375	450												
250kg	ER2M003IS-IS														
		ER2M003IH-IS						27							
500kg	ER2M005IL-IS	395	510	315	220	515	179		95	22	130	205	100	51	31
1	ER2M010IL-IS	435	550					31							
1.6	ER2M016IS-IS	505						34							
2	ER2M020IL-IS	570	630	325	225	520	184		110	27	125	212	118	60	36
		ER2M020IS-IS													
2.5	ER2M025IS-IS	620	830	340	226	521	186		125	20	131	215	132	68	43
3.2	ER2M032IS-IS	765	900					44							
5	ER2M050IS-IS	840	910	400	281	528	102	47	140	44	145	233	150	86	54