

ER2 Dual Speed
 Artikelnummer ER2 Dual Speed



Omschrijving

Standaard met 5 meter stroomkabel.

De lengte van de ketting, een afstandbediening en stroomkabels zijn vrijblijvend.

Verlenging van de ketting is strikt verboden.

Een stalen ketting container is mogelijk op aanvraag.

Standaard

Opties



Type

Specifications

Capacity (t)	Product Code	Hoist Body	Standard Lift (m)	Push Button Cord L (m)	Lifting Motor		Lifting Speed (m/min)*		Load Chain		Classification ISO/FEM/ASME	Test Load (t)	Net Weight (kg)	Additional Weight per 1m Lift (kg)
					Output (kW)	Rating (%ED)	50Hz		Diameter (mm) x Chain Falls					
							High	Low						
125kg	ER2-001IH	B			0.56		Preset	10.6	2.8	4.3 x 1		156kg	27	0.42
	Adjustable						1.4	1.8						
250kg	ER2-003IS				0.0		Preset	10.8	0.9			313kg	36	
	Adjustable						2.0	1.2						
500kg	ER2-003IH				0.0		Preset	15.7	2.0	6 x 1	M5/2m/H4	625kg	32	0.81
	Adjustable						1.2	0.7						
1	ER2-005IL	C		2.5	0.56		Preset	4.5	0.8	7.7 x 1		1.25	45	1.33
	Adjustable						0.4	0.3						
1.6	ER2-005IS				0.0	40/20	Preset	8.2	1.4			2	72	
	Adjustable						0.7	0.4						
2	ER2-010IL	D	3		1.8		Preset	5.3	0.9	10.2 x 1		2.5	73	2.3
	Adjustable						0.4	0.3						
1.6	ER2-016IS				1.8		Preset	8.2	1.4			2	72	
	Adjustable						0.7	0.4						
2	ER2-020IL	E			0.0		Preset	4.3	0.4	11.2 x 1	M4/1Am/H4	3.13	100	2.8
	Adjustable						0.4	0.3						
2.5	ER2-020IS				3.5		Preset	8.2	0.7	10.2 x 2		4	105	4.7
	Adjustable						1.2	0.7						
3.2	ER2-025IS	F			3.5		Preset	6.0	1.1	11.2 x 2		6.25	128	5.6
	Adjustable						0.6	0.6						
3.2	ER2-032IS	E			3.5		Preset	5.2	0.9			4	105	4.7
	Adjustable						0.4	0.4						
5	ER2-050IS	F		2.8	3.5		Preset	3.3	0.6			6.25	128	5.6
	Adjustable						0.3	0.3						

Note: The high speed is preset to the maximum speed in KITO factory. The speeds are adjustable between High and Low.



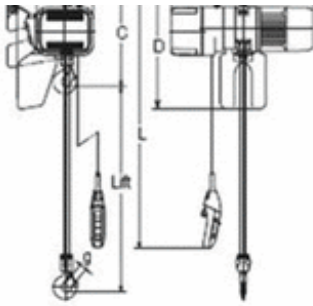

Dimensions (mm)

Capacity (t)	Product Code	Headroom C	D	a	b	d	e	f	g	h	i
125kg	ER2-001IH	350	430	535	345	276	259	284	27	99	117
250kg	ER2-003IS			568							
500kg	ER2-003IH	370	400	571	348	300	268	263	27	113	106
	ER2-005IS			568			266				
1	ER2-010IL	430	550	614	376	316	296	335	31	120	118
	ER2-010IS			623			307				
1.6	ER2-016IS	510	630	710	427	372	338	384.5	34	160.5	137.5
2	ER2-020IL	575		767					411		
	ER2-020IS	590									
2.5	ER2-025IS	625	840	800	445	401	399	437.5		173.5	142.5
3.2	ER2-032IS	785	920	767	427	411	356	397	44	216	82
5	ER2-050IS	850		800	445	401	399	439	47	231.5	84.5